

20010**HS**-NN

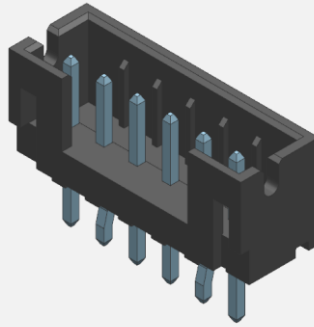

20010**WS**-NN

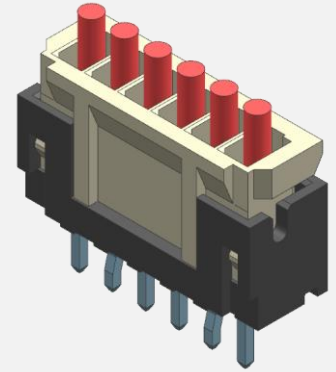

Mating View

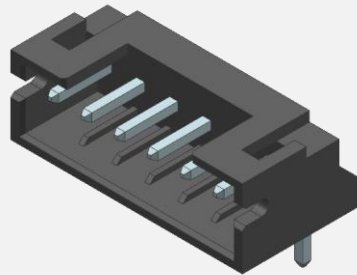

20010**WR**-NN

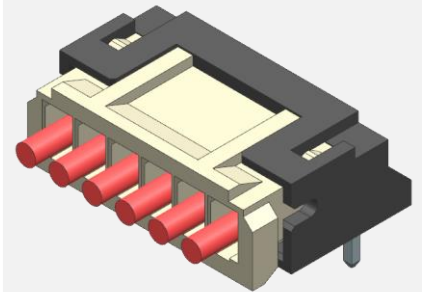

Mating View

□ Feature

1. This Product is a Wire to board Connector
2. Product Height is 4.7mm , 7.8mm
3. This Connector Type is Vertical , Horizontal
4. Uses this connector in Wave soldering

□ Product Specification

Item	Specification
Operating Voltage	AC/DC 250V
Current Rating	AC/DC 2A
Operating Temperature	-25°C ~ +85°C
Insulation resistance	1000MΩ
Withstanding voltage	No flash over and no physical damage
Contact resistance	30mΩ MAX
Durability	Contact Resistance : 50mΩ MAX
Vibration	1) Contact Resistance : 50mΩ MAX 2) Discontinue : 1μsec MAX

□ Ordering Code

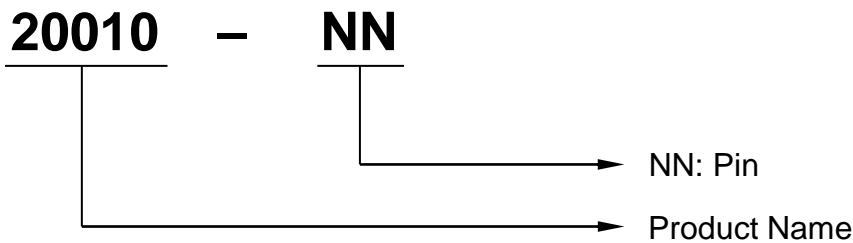

□ Material / Plating

Part	Material	Plating / Color
Wafer	PA계열	White
Pin	Copper Alloy	Sn Plating
Housing	PA계열	White
Terminal	Copper Alloy	Sn Plating

□ Connector Dimension/ 20010WR-NN

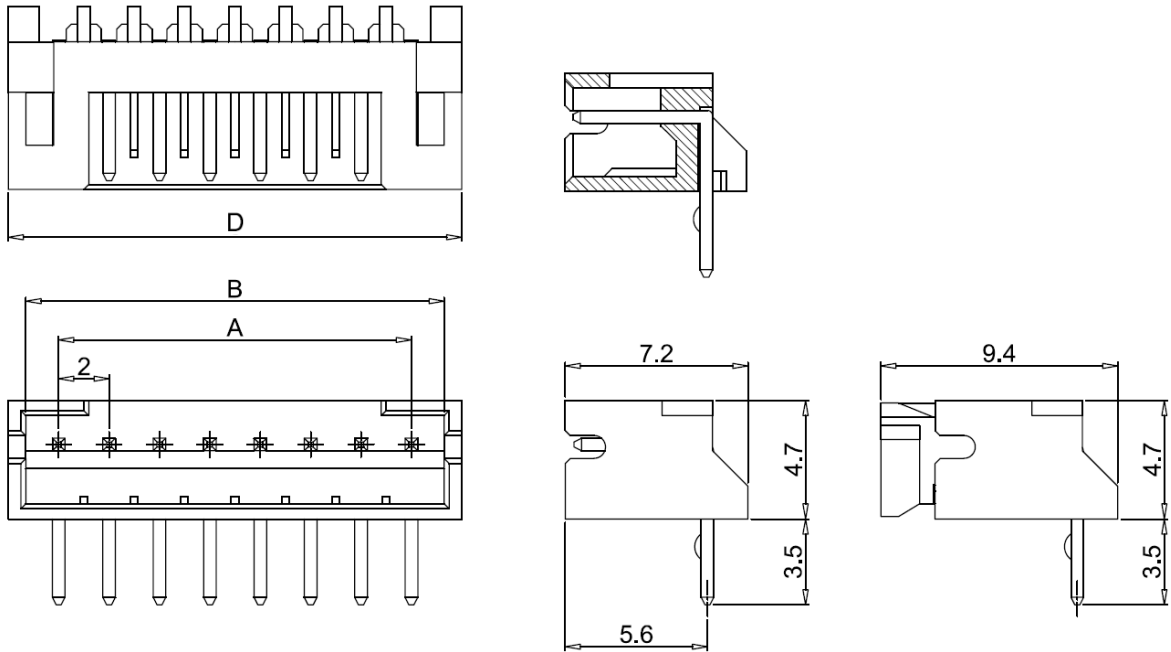

Part No.	Pin	A	B	D
20010WR-02	2	2	4.6	6
20010WR-04	4	6	8.6	10
20010WR-06	6	10	12.6	14
20010WR-08	8	14	16.6	18
20010WR-10	10	18	20.6	22
20010WR-12	12	22	24.6	26
20010WR-14	14	26	28.6	30
20010WR-16	16	30	32.6	34

※ Contact Yeonho Sales representative if considering use of non-specified circuits

□ Connector Dimension/ 20010WS-NN

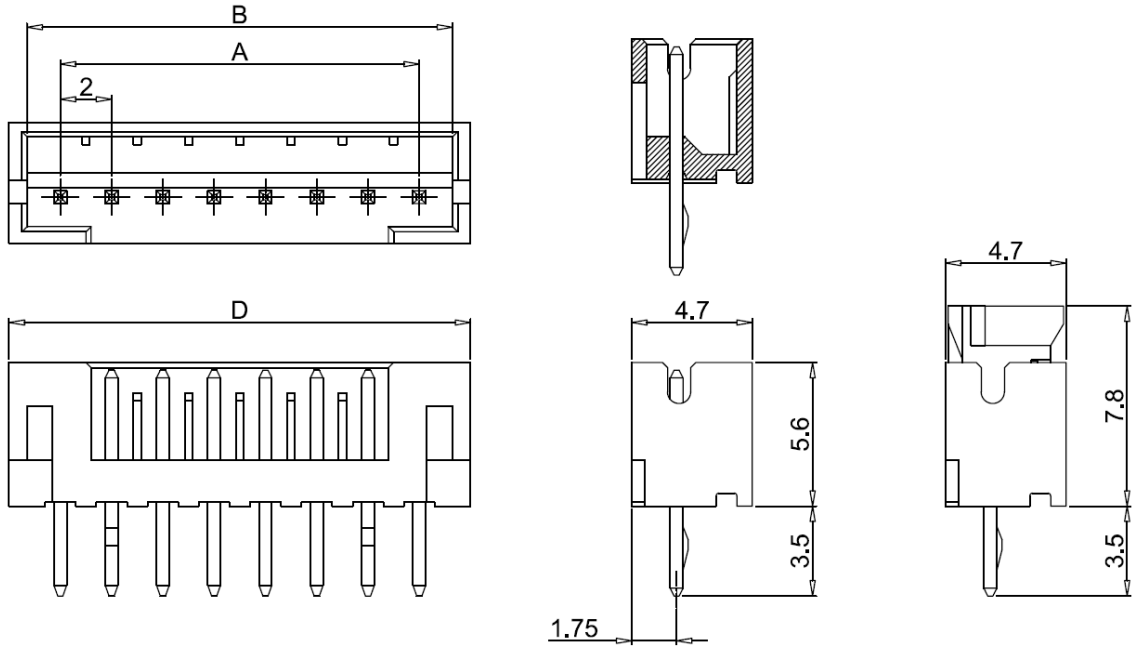

Part No.	Pin	A	B	C
20010WS-02	2	2	4.6	6
20010WS-04	4	6	8.6	10
20010WS-06	6	10	12.6	14
20010WS-08	8	14	16.6	18
20010WS-10	10	18	20.6	22
20010WS-12	12	22	24.6	26
20010WS-14	14	26	28.6	30
20010WS-16	16	30	32.6	34

※ Contact Yeonho Sales representative if considering use of non-specified circuits

□ PCB Pattern Dimension/ 20010WR,WS-HNN

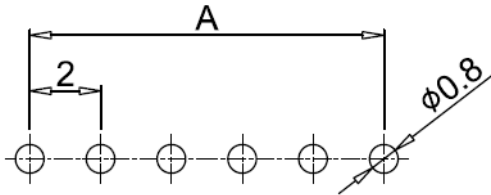

Pin	A
2	2
4	6
6	10
8	14
10	18
12	22
14	26
16	30

※ Contact Yeonho Sales representative if considering use of non-specified circuits

□ Connector Dimension/ 20010HS-NN

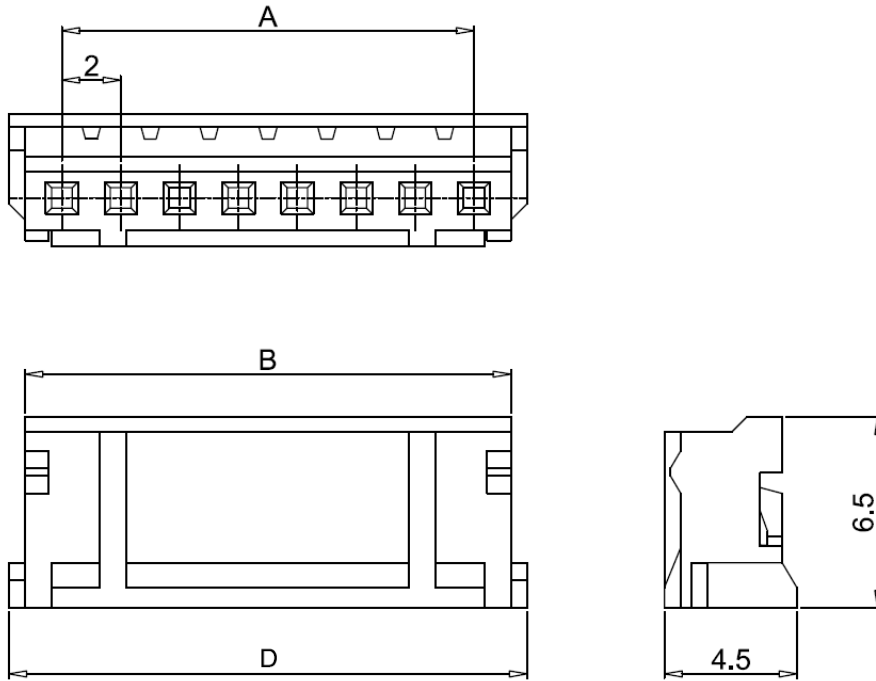

Part No.	Pin	A	B	D
20010HS-02	2	2	4.5	5.6
20010HS-04	4	6	8.5	9.6
20010HS-06	6	10	12.5	13.6
20010HS-08	8	14	16.5	17.6
20010HS-10	10	18	20.5	21.6
20010HS-12	12	22	24.5	25.6
20010HS-14	14	26	28.5	29.6
20010HS-16	16	30	32.5	33.6

※ Contact Yeonho Sales representative if considering use of non-specified circuits

❑ Connector Dimension/ 20010TS

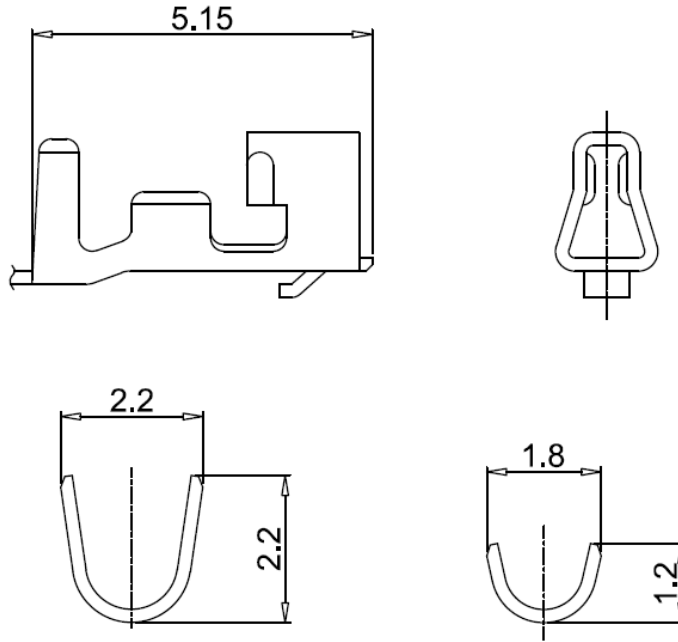

Part Name	Housing Name	Plating	Wire Size
20010TS	20010HS-NN	Sn Plating	AWG#24~#26

※ Contact Yeonho Sales representative if considering use of non-specified circuits